

Equinox is made from an easy to maintain Fluid Concrete Technology that is light enough to allow for flexibility yet durable enough for long-term use in residential and commercial settings alike. Available in a natural concrete finish with your choice of burner system (bioethanol, natural gas or propane), Equinox is 65" (1650mm) long and can be extended to any length by using its modular counterparts - Solstice or Horizon.

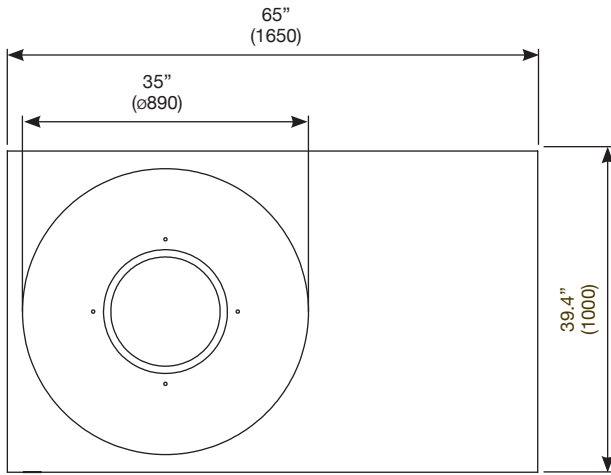

EQUINOX

DIMENSIONS



Top View



Front View



MATERIALS

Fluid Concrete Technology* surround, Grade 304 Stainless Steel Burner with glass charcoal.

*Concrete is a natural material. Each piece is hand made. Pieces are similar, but no two pieces are identical in color or appearance.

WEIGHT

164lbs [74.6kg]

(Includes burner and glass charcoal)

MODEL OPTIONS

Fuel	Color	SKU
LP/NG	Natural	BJF.2.EQU.NA.G
	Graphite	BJF.2.EQU.GH.G
	Bone	BJF.2.EQU.BO.G
	Rust	BJF.2.EQU.RU.G
Bioethanol	Natural	BJF.2.EQU.NA.E
	Graphite	BJF.2.EQU.GH.E
	Bone	BJF.2.EQU.BO.E
	Rust	BJF.2.EQU.RU.E

HEAT OUTPUT

Fuel	BTU/Hr	Burn Hours*
LP	55,000	8 - 20
NG	55,000	Unlimited
Bioethanol	20,000	7 - 11

*These values are indicative only. LP/NG Burners are UL/ULC Listed. Bioethanol Burner is UL Listed.

OPTIONAL ACCESSORIES

Accessory	SKU
Outdoor Cover	BJF.1.C.EQU/FLO
Glass Screen	BLD.1.A.G.R650
Horizon (Cocktail Table)	BJF.2.HRZ
Look (Stool or Side Table)	BJF.2.S.LOK
Loop Stool (or Side Table)	BJF.2.S.LPB
Hideout (Tank Cover or Side Table)	BJF.2.HDT
Pivot (Stool or Side Table)	BJF.2.S.PVT



TABLES - LOW

Disclaimer: All product specifications and data are subject to change without notice and believed to be correct at the time of publication. The Fire Company Pty Ltd (TFC), its affiliates, agents, and employees, and all persons acting on its or their behalf (collectively, "The Fire Company"), disclaim any and all liability for any errors, inaccuracies or incompleteness contained herein or in any other disclosure relating to any product. TFC disclaims any and all liability arising out of the use or application of any product described herein or of any information provided herein to the maximum extent permitted by law. The product specifications do not expand or otherwise modify TFC P/L's terms and conditions of purchase, including but not limited to the warranty expressed therein, which apply to these products. No license, express or implied, by estoppel or otherwise, to any intellectual property rights is granted by this document or by any conduct of TFC. Customers using or selling TFC products not expressly indicated for use in such applications do so entirely at their own risk and agree to fully indemnify TFC for any damages arising or resulting from such use or sale. Please contact authorized personnel from TFC to obtain written terms and conditions regarding products designed for such applications. **Brown Jordan is a trademark of Brown Jordan International, Inc. and is used under license to EcoSmart Inc.** © 2017 V1217