

XS340

ecosmart⁺
Fire

A compact linear burner. Clever design and smaller dimensions enable XS340 to be incorporated into smaller or recessed spaces.



Design Features

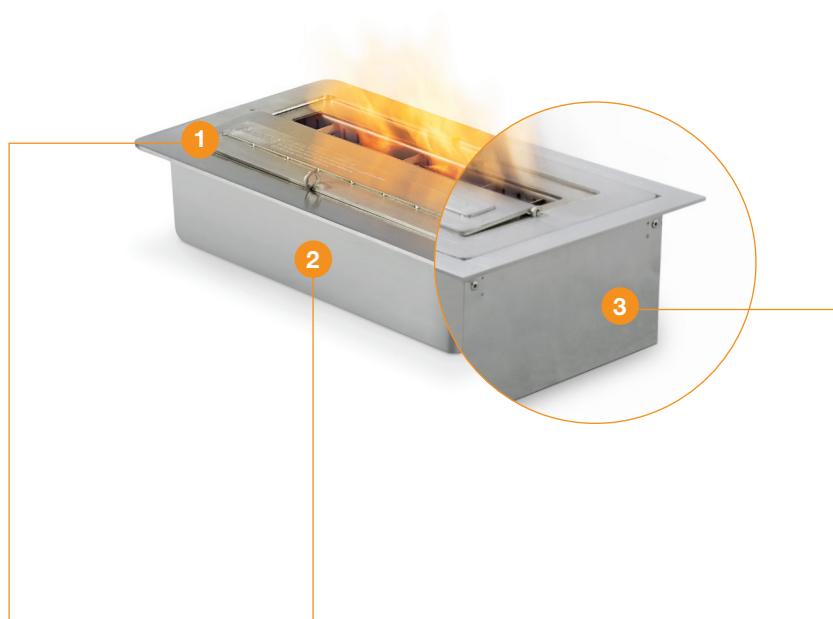

1. Flip Lid Shut Off System

The 'flip lid' shut-off system fits perfectly across the ignition zone to extinguish the flame and, when it is open, denies access to the separated filling point as a deterrent to filling the burner while it is in operation.

A reliable and safe extinguishing system courtesy of a special shut-off mechanism and precision measurements.

Signature Style

Clever design and compact size enable the XS340 to be incorporated into smaller or recessed spaces. Indoor or out, the choice is yours.

2. High Quality

Crafted from high quality, 304 grade stainless steel, EcoSmart Fire burners are built to last a lifetime.

No Flue, No Chimney, No Vent

Fuelled by clean-burning e-NRG bioethanol our burners produce a beautiful orange flame without any smoke, soot or ash.

Easy to Clean

Our bioethanol burners can be washed in hot water (or even put in your dishwasher), a key competitive difference.

Colour

Available in Stainless Steel and Black.

The Perfect Fit

The streamlined design of the products synchronises effortlessly within award-winning architectural projects.

3. Top Tray

If installing a Burner indoors, a Top Tray must be incorporated into your setting before operating the appliance.

The incorporation of a Top Tray protects against heat transference and aids in the collection of accidental spillage.

Top Trays can be sourced from your local distributor, if not included in your order at time of purchase.

Global Compliance

All burners are OMNI-Test Laboratories Inc. listed in accordance with UL 1370-16 "Standard for Unvented Alcohol Fuel Burning Decorative Appliances" in the USA, are certified by BSI in accordance with EN16647, and comply with the ACCC Safety Mandate for Australia.

Accessories

Included



Jerry Can with Safety Spout and e-NRG bottle adaptor

Jerry Can allows safe storing/decanting of e-NRG* ethanol. The e-NRG adaptor connects the Safety Spout to an e-NRG fuel bottle.



Lighting Rod & Lighter

The Lighting Rod is designed to safely adjust the slider position on the burner. It is also used for the ignition procedure.

Optional



Decorative Glass Media

Our decorative Black Glass Charcoal is made from high-quality tempered glass.

Not to be placed directly on top of the burner or anywhere they can interfere with the operation of the burner or the stability of flame.



Plasma Fire Screen

A freestanding Fire Screen supported by stainless steel feet, elevating the screen as if floating, while providing enhanced stability.



Twin Feet Fixings

These stainless steel feet secure a custom glass fire screen in place, offering easy stability while allowing easy removal for refueling and maintenance.

*e-NRG not available in all countries.

Disclaimer: All product specifications and data are subject to change without notice and believed to be correct at the time of publication. MAD Design Group (MDG), its affiliates, agents, and employees, and all persons acting on its or their behalf (collectively, "MAD Design Group"), disclaim any and all liability for any errors, inaccuracies or incompleteness contained herein or in any other disclosure relating to any product. MDG disclaims any and all liability arising out of the use or application of any product described herein or of any information provided herein to the maximum extent permitted by law. The product specifications do not expand or otherwise modify MDG's terms and conditions of purchase, including but not limited to the warranty expressed therein, which apply to these products. No license, express or implied, by estoppel or otherwise, to any intellectual property rights is granted by this document or by any conduct of MDG. Customers using or selling MDG products not expressly indicated for use in such applications do so entirely at their own risk and agree to fully indemnify MDG for any damages arising or resulting from such use or sale. Please contact authorised personnel from MDG to obtain written terms and conditions regarding products designed for such applications. Images are indicative only.

Specifications (Outdoor)

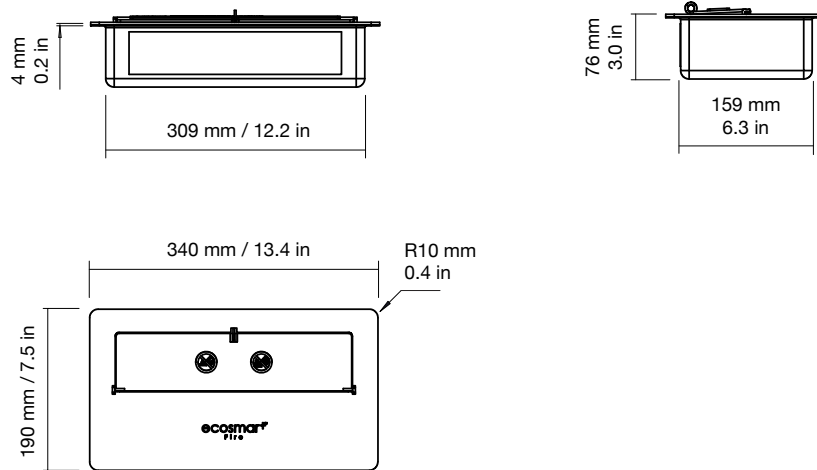

ESF.B.XS3

Product Dimensions

L 340 mm [13.4 in]
W 190 mm [7.5 in]
D 76 mm [3.0 in]

Weight (approx)

3.7 kg [8.1 lb]

Product Materials

Grade 304 Stainless Steel (With Optional Black Ceramic Coating)

Colours

Stainless Steel or Black



Burner Ventilation and Efficiency*

Fuel Type	Fuel Capacity	Heats on Average (Indoors)	Fuel Consumption	Thermal Output Net (MAX per burner)	Approx. Burn Time	Minimum Room Size	Application ¹
e-NRG Bioethanol e-NRG.com	2.5 L [0.7 Gal]	Over 20 m ² [215 ft ²]	0.45 L/h [0.12 Gal/h]	8.93 MJ/h, 8,530 BTU/h, 2.5 kW	5 hours	45 m ³ [1,589 ft ³]	Outdoor

*These values are indicative only and may vary depending on the model purchased, installation, and the seasonal resource used to manufacture e-NRG.

¹For Indoor Use, additional parts are required. Your chosen application is the ONLY application the model can be used in due to modified configuration of the model. Please advise your Sales Representative at time of purchase so that the product can be configured accordingly.

Read the manual carefully before operating the burner. Physical model dimensions should be verified against cut out dimensions BEFORE installation begins to confirm tolerances align.

This model complies with existing standards in the USA, Europe, UK and Australia. O-TL listed to UL1370, EN 16647 BSI Certified and ACCC Safety Mandate compliant. To comply with EN 16647 (EU, UK, AU) a Top Tray must be used before operating indoors.

For more information please reference the Clearance & Installation Manual

Disclaimer: All product specifications and data are subject to change without notice and believed to be correct at the time of publication. MAD Design Group (MDG), its affiliates, agents, and employees, and all persons acting on its or their behalf (collectively, "MAD Design Group"), disclaim any and all liability for any errors, inaccuracies or incompleteness contained herein or in any other disclosure relating to any product. MDG disclaims any and all liability arising out of the use or application of any product described herein or of any information provided herein to the maximum extent permitted by law. The product specifications do not expand or otherwise modify MDG's terms and conditions of purchase, including but not limited to the warranty expressed therein, which apply to these products. No license, express or implied, by estoppel or otherwise, to any intellectual property rights is granted by this document or by any conduct of MDG. Customers using or selling MDG products not expressly indicated for use in such applications do so entirely at their own risk and agree to fully indemnify MDG for any damages arising or resulting from such use or sale. Please contact authorised personnel from MDG to obtain written terms and conditions regarding products designed for such applications. Images are indicative only.

Specifications (Indoor)

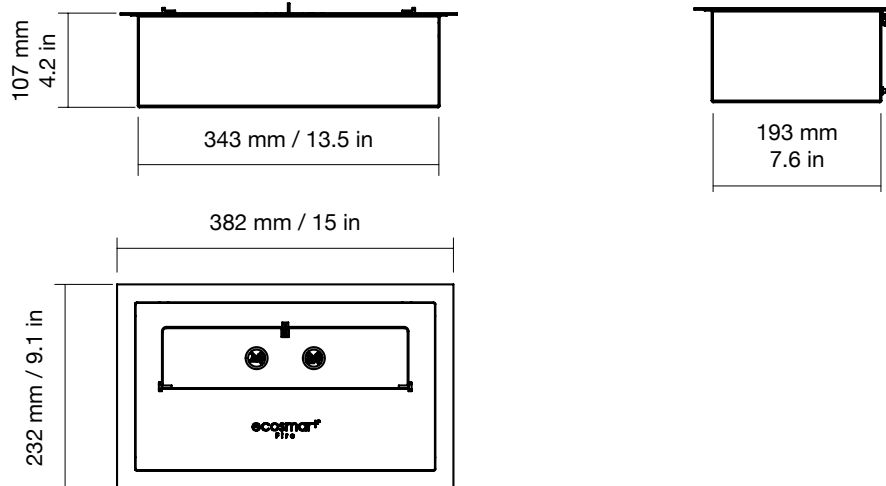

ESF.B.XS3.WTT

Product Dimensions

L 382 mm [15 in]
W 232 mm [9.1 in]
D 107 mm [4.2 in]

Weight (approx)

5.4 kg [11.9 lb]

Product Materials

Grade 304 Stainless Steel (With Optional Black Ceramic Coating)

Colours

Stainless Steel or Black



Burner Ventilation and Efficiency*

Fuel Type	Fuel Capacity	Heats on Average (Indoors)	Fuel Consumption	Thermal Output Net (MAX per burner)	Approx. Burn Time	Minimum Room Size	Application ¹
e-NRG Bioethanol e-NRG.com	2.5 L [0.7 Gal]	Over 20 m ² [215 ft ²]	0.45 L/h [0.12 Gal/h]	8.93 MJ/h, 8,530 BTU/h, 2.5 kW	5 hours	45 m ³ [1,589 ft ³]	Indoor

*These values are indicative only and may vary depending on the model purchased, installation, and the seasonal resource used to manufacture e-NRG.

¹For Indoor Use, additional parts are required. Your chosen application is the ONLY application the model can be used in due to modified configuration of the model. Please advise your Sales Representative at time of purchase so that the product can be configured accordingly.

Read the manual carefully before operating the burner. Physical model dimensions should be verified against cut out dimensions BEFORE installation begins to confirm tolerances align.

This model complies with existing standards in the USA, Europe, UK and Australia. O-TL listed to UL1370, EN 16647 BSI Certified and ACCC Safety Mandate compliant. To comply with EN 16647 (EU, UK, AU) a Top Tray must be used before operating indoors.

For more information please reference the Clearance & Installation Manual

Disclaimer: All product specifications and data are subject to change without notice and believed to be correct at the time of publication. MAD Design Group (MDG), its affiliates, agents, and employees, and all persons acting on its or their behalf (collectively, "MAD Design Group"), disclaim any and all liability for any errors, inaccuracies or incompleteness contained herein or in any other disclosure relating to any product. MDG disclaims any and all liability arising out of the use or application of any product described herein or of any information provided herein to the maximum extent permitted by law. The product specifications do not expand or otherwise modify MDG's terms and conditions of purchase, including but not limited to the warranty expressed therein, which apply to these products. No license, express or implied, by estoppel or otherwise, to any intellectual property rights is granted by this document or by any conduct of MDG. Customers using or selling MDG products not expressly indicated for use in such applications do so entirely at their own risk and agree to fully indemnify MDG for any damages arising or resulting from such use or sale. Please contact authorised personnel from MDG to obtain written terms and conditions regarding products designed for such applications. Images are indicative only.

Cut-out dimensions

Physical model dimensions should be verified against cut out dimensions BEFORE installation begins to confirm tolerances align.

Outdoor Application Burner Without Top Tray

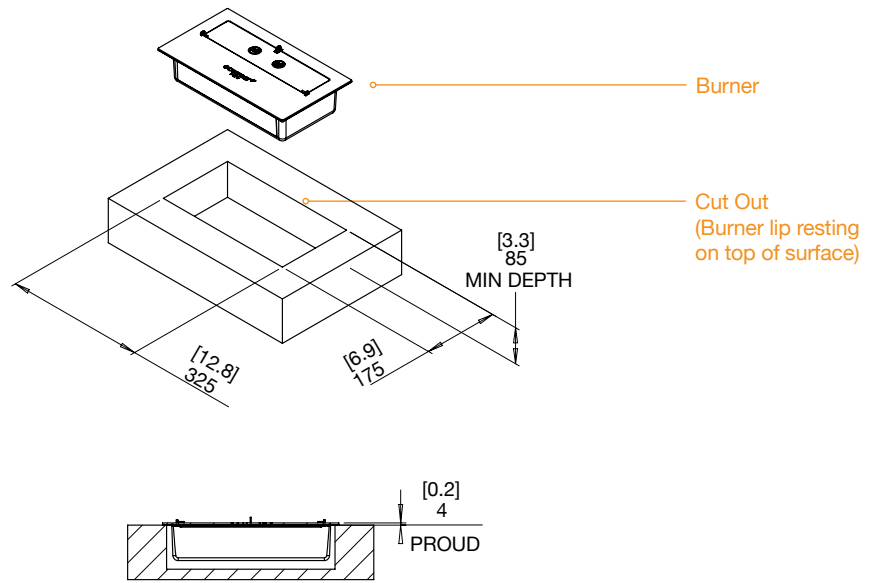

Indoor Application Burner With Top Tray

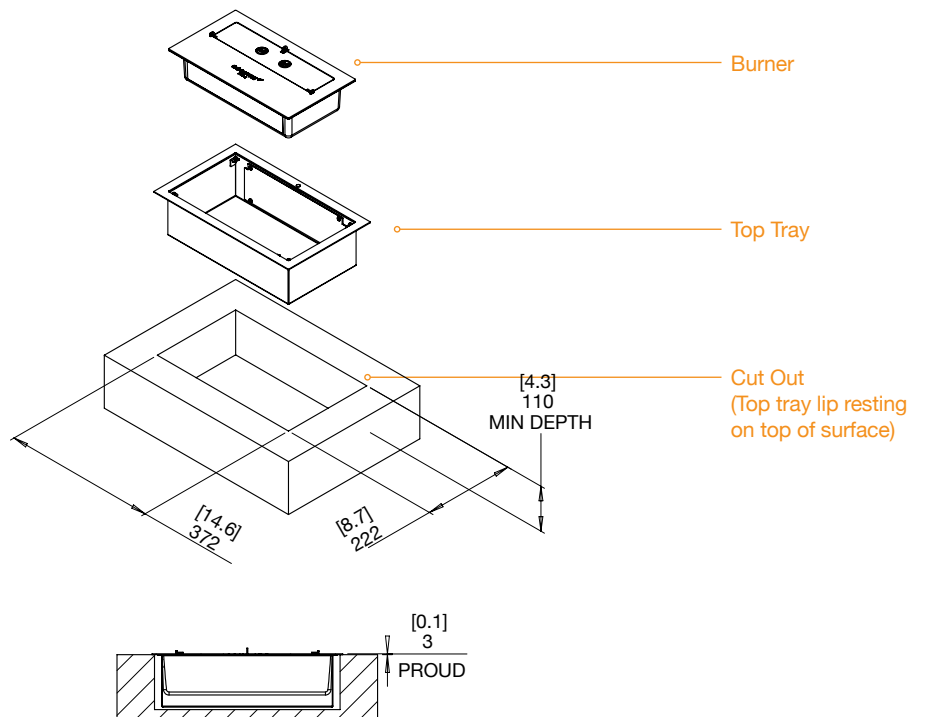

Disclaimer: All product specifications and data are subject to change without notice and believed to be correct at the time of publication. MAD Design Group (MDG), its affiliates, agents, and employees, and all persons acting on its or their behalf (collectively, "MAD Design Group"), disclaim any and all liability for any errors, inaccuracies or incompleteness contained herein or in any other disclosure relating to any product. MDG disclaims any and all liability arising out of the use or application of any product described herein or of any information provided herein to the maximum extent permitted by law. The product specifications do not expand or otherwise modify MDG's terms and conditions of purchase, including but not limited to the warranty expressed therein, which apply to these products. No license, express or implied, by estoppel or otherwise, to any intellectual property rights is granted by this document or by any conduct of MDG. Customers using or selling MDG products not expressly indicated for use in such applications do so entirely at their own risk and agree to fully indemnify MDG for any damages arising or resulting from such use or sale. Please contact authorised personnel from MDG to obtain written terms and conditions regarding products designed for such applications. Images are indicative only.