

Heritage Grate 50

ecosmart⁺
Fire

Transform your traditional wood-burning fireplace into a modern, clean-burning centerpiece in minutes with Heritage Grates. Featuring ceramic fire-rated wood logs and a classic iron grate design, it offers the timeless charm of a traditional fireplace without the hassle of soot, ash, or smoke.



Heritage Grate 50

Design Features



1. Surround Colour

Heritage Grates are crafted using 1.2mm SECC steel for the tray and 10mm SECC steel for the bars, all finished with a high-temperature black powder coating for durability and style.

Available in Two Sizes

The Heritage Grate series is available in two sizes: **Heritage Grate 25**, a compact option featuring the BK5 Burner, and **Heritage Grate 50**, a longer model with the XL900 Burner. With these two sizes, you can easily find the perfect fit for your existing fireplace.

2. Burner Colours

Heritage Grate 50 comes with a stainless steel burner, and offers the option of a black burner.

Convert an Existing Fireplace in Minutes

Transforming an existing wood burning fire into a clean burning bioethanol fireplace is easy. Simply install the grate on a level platform and fill it with liquid bioethanol. Then sit back and relax.

3. Traditional Aesthetic

Ceramic fire-rated wood logs and the iron grate design create a classic fireplace look.

No Flue, No Chimney, No Vent

Fuelled by clean-burning e-NRG bioethanol, our burners produce a beautiful orange flame without any smoke, soot or ash.

Low Maintenance

Bioethanol Fireplaces don't leave any carbon residue, so they are incredibly easy to keep clean. Just wipe them down with a damp cloth every now and then.

Warm your Home, Not the Planet

Burning bioethanol fuel doesn't produce any smoke, so you can use an EcoSmart smokeless fireplace grate with or without an operational chimney.

As traditional wood burning fireplaces lose a lot of heat through the chimney, we recommend sealing off the chimney to increase efficiency. You can do this by closing the dampener or blocking off the chimney with a metal plate.

Global Compliance

These models comply with existing standards in the USA, Europe, UK and Australia. O-TL listed to UL1370, EN 16647 BSI Certified and ACCC Safety Mandate compliant.

Heritage Grate 50

Accessories

Included



Jerry Can with Safety Spout and e-NRG* bottle adaptor

Jerry Can allows safe storing/decanting of e-NRG ethanol. The e-NRG adaptor connects the Safety Spout to an e-NRG fuel bottle.



Lighting Rod & Lighter

The Lighting Rod is designed to safely adjust the slider position on the burner. It is also used for the ignition procedure.



XL Baffles

Placed over the internal burner vents, they serve to increase the efficiency of the burner as well as further stabilise the flame.



Decorative Ceramic Logs

Engineered to mimic wood, our ceramic logs provide an authentic visual experience without ash, debris or residue.

Optional



Plasma Fire Screen

A freestanding Fire Screen supported by stainless steel feet, elevating the screen as if floating, while providing enhanced stability.



Twin Feet Fixings

These stainless steel feet secure a custom glass fire screen in place, offering stability while allowing easy removal for refueling and maintenance.

*e-NRG not available in all countries.

Disclaimer: All product specifications and data are subject to change without notice and believed to be correct at the time of publication. MAD Design Group (MDG), its affiliates, agents, and employees, and all persons acting on its or their behalf (collectively, "MAD Design Group"), disclaim any and all liability for any errors, inaccuracies or incompleteness contained herein or in any other disclosure relating to any product. MDG disclaims any and all liability arising out of the use or application of any product described herein or of any information provided herein to the maximum extent permitted by law. The product specifications do not expand or otherwise modify MDG's terms and conditions of purchase, including but not limited to the warranty expressed therein, which apply to these products. No license, express or implied, by estoppel or otherwise, to any intellectual property rights is granted by this document or by any conduct of MDG. Customers using or selling MDG products not expressly indicated for use in such applications do so entirely at their own risk and agree to fully indemnify MDG for any damages arising or resulting from such use or sale. Please contact authorised personnel from MDG to obtain written terms and conditions regarding products designed for such applications. Images are indicative only.

Heritage Grate 50

Specifications

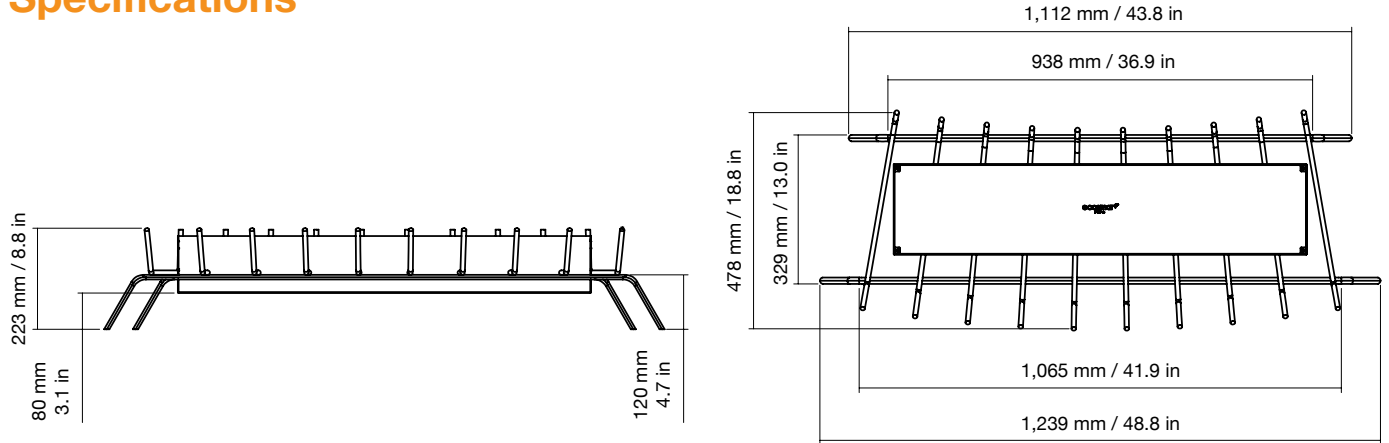

ESF.G.HG.50

Product Dimensions

W 1,239 mm [48.8 in]
D 478 mm [18.8 in]
H 223 mm [8.8 in]

Weight (approx)

25.1 kg [55.2 lb]
Weight includes burner.

Product Materials

1.2mm SECC steel tray and 10mm SECC steel bars with Hi-temp Powder Coat; Grade 304 Stainless Steel (Optional Black Ceramic Coating) Burner.

Surround Colour

Black



Burner Colours

Stainless Steel or Black



Burner Ventilation and Efficiency*

Fuel Type	Compatible Burner	Fuel Capacity	Heats on Average (Indoors)	Thermal Output Net (MAX per burner)	Approx. Burn Time	Minimum Room Size	Application
e-NRG Bioethanol e-NRG.com	XL900	9 L [2.4 Gal]	Over 60 m ² [645 ft ²]	16 MJ/h, 15,000 BTU/h, 4.4 kW	8 - 13 hours	110 m ³ [3,884 ft ³]	Indoor

*These values are indicative only and may vary depending on the model purchased, installation, and the seasonal resource used to manufacture e-NRG.

This model complies with existing standards in the USA, Europe, UK and Australia. O-TL listed to UL1370, EN 16647 BSI Certified and ACCC Safety Mandate compliant

For more information please reference the Clearance & Installation Manual

Disclaimer: All product specifications and data are subject to change without notice and believed to be correct at the time of publication. MAD Design Group (MDG), its affiliates, agents, and employees, and all persons acting on its or their behalf (collectively, "MAD Design Group"), disclaim any and all liability for any errors, inaccuracies or incompleteness contained herein or in any other disclosure relating to any product. MDG disclaims any and all liability arising out of the use or application of any product described herein or of any information provided herein to the maximum extent permitted by law. The product specifications do not expand or otherwise modify MDG's terms and conditions of purchase, including but not limited to the warranty expressed therein, which apply to these products. No license, express or implied, by estoppel or otherwise, to any intellectual property rights is granted by this document or by any conduct of MDG. Customers using or selling MDG products not expressly indicated for use in such applications do so entirely at their own risk and agree to fully indemnify MDG for any damages arising or resulting from such use or sale. Please contact authorised personnel from MDG to obtain written terms and conditions regarding products designed for such applications. Images are indicative only.